

Date	19/05/2016
Number	0682
Pages	8

### TECHNICAL INFORMATION

MODEL	MT09 / MT09A / FZ09 / MT09TRA / FJ09
SUBJECT	CAM CHAIN TENSIONER (CCT) NOISE

#### PROBLEM:

Some MT09 owners complained about noise from the right side of the engine even after replacing the tensioner with the improved one.

#### CAUSE:

The contact between the threaded half nut and retaining surface damaged due to insufficient lubrication. The wear results in reduced friction and move the half-nut. As a result, the tensioner is not held taut and the chain oscillates causing noise.

#### Tensioner Construction:

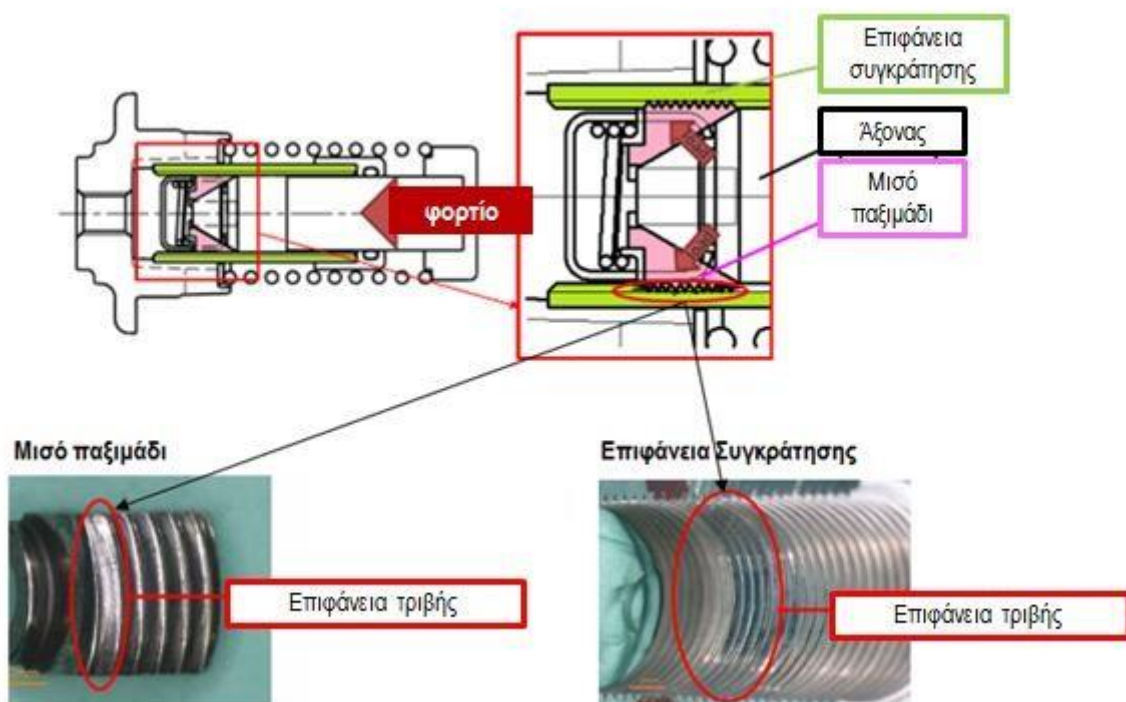

## **FACTORY SOLUTION:**

The way lubrication changed from splashing in pressure lubrication.

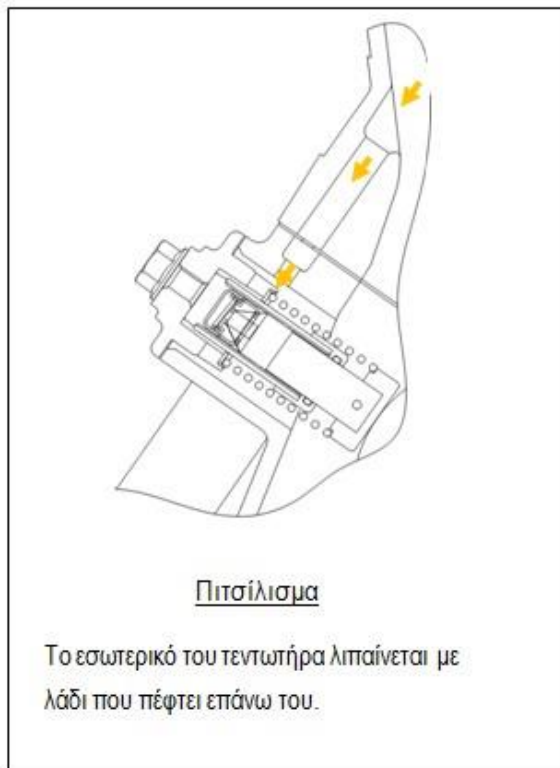

## **RANGE OF IMPROVED VEHICLES:**

MODEL	CHASSIS NUMBER
MT09 FZ09	RN291-0005515 and after
	RN292-0004548 and after
	RN33E-0010609 and after
	RN33Y-0003073 and after
	RN33N-0002102 and after
MT09A	RN296-0014569 and after
	RN297-0002932 and after
	RN441-0000125 and after
MT09TRA FJ09	RN29F-0015339 and after
	RN29G-0003516 and after
	RN29K-0000696 and after
	RN37E-0003117 and after
	RN37Y-0000866 and after
	RN37N-0000837 and after

## **PART NUMBER INFORMATION**

DESCRIPTION	OLD CODE	NEW CODE	QTY
TENSIONER	1RC-12210-04	B90-12210-00	1

### INTERCHANGEABILITY:

Old cam chain tensioner (CCT) cannot be replaced from the new one.

### IDENTIFICATION OF SPARE PART

The color identification sign has changed

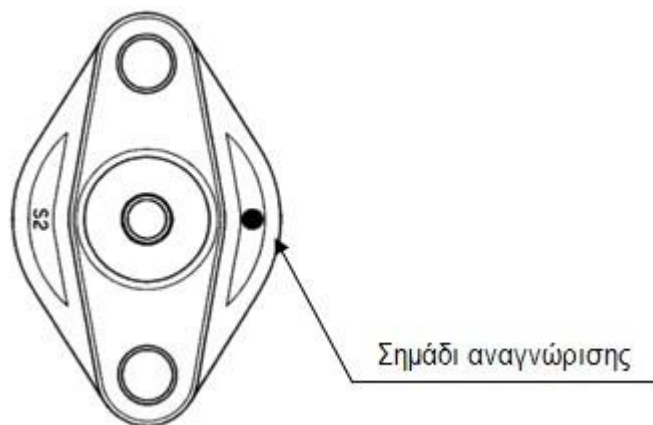

CODE	IDENTIFICATION COLOR
1RC-12210-04	YELLOW
B90-12210-00	BROWN

### SOLUTION FOR VEHICLES ALREADY ON THE ROAD:

The existing oil flow is changed in a way that improves the lubrication of the tensioner.

One of the head cap screws is replaced with a bearing inner oil passage to convey oil from the easel camshaft on the roller.

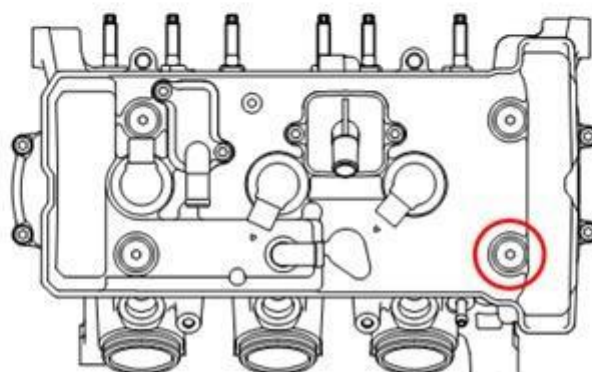

To effectively lubricated inside the tensioner, the inner flange of the tensioner grew to drive more oil in disputed wear point of the tensioner.

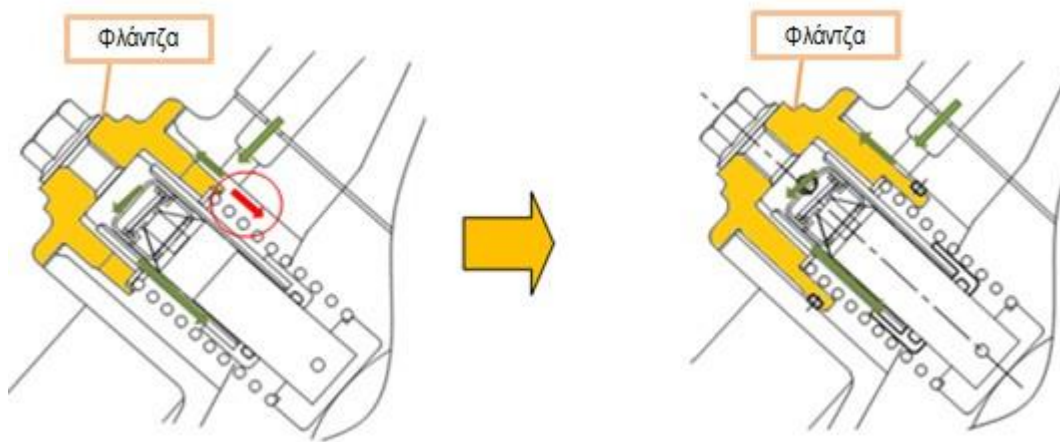

In case of a problem, replace the tensioner and place all the parts of improved kit.

Because there are two types of crankcase due to a change made in the production of October 2015, there are 2 types of tensioners which are differentiated mainly by the shape of the groove in the body. So there are two booster kit available.

**IMPROVEMENT TENSIONER KIT 1 (P / N: 90891-10272)**

No.	Description	Code	Quantity
1	TENSIONER ASSY	1RC-12210-09	1
2	RING	1RC-14633-09	1
3	COLLAR	1RC-11478-09	1
4	GASKET	90430-006166	1
5	BOLT	1RC-12157-09	1

\* The tensioner gasket is not included in the kit - order separately.



**IMPROVEMENT TENSIONER KIT 2 (P/N: 90891-10274)**

No.	Description	Code	Quantity
1	TENSIONER ASSY	1RC-12210-08	1
2	COLLAR	1RC-11478-09	1
3	GASKET	90430-06166	1
4	BOLT	1RC-12157-09	1

\*Η φλάντζα τεντωτήρα δεν περιλαμβάνεται στο κιτ – παραγγείλτε την χωριστά.

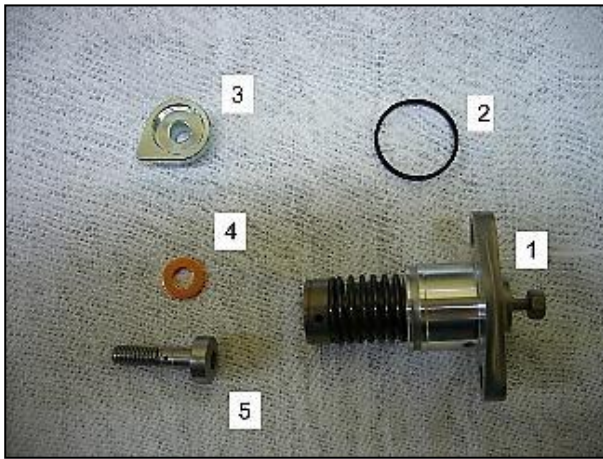

**KIT CHOICE ACCORDING TO CHASSIN NUMBER**

MODEL	TYPE	IMPROVEMENT TENSIONER KIT 1		IMPROVEMENT TENSIONER KIT 2	
		FROM	TO	FROM	TO
MT09 FZ09	RN291	0000301	0005508	0005509	0005514
	RN292	0000301	0004546	0004547	0004547
	RN294	0000003	0001791		-
	RN295	0000301	0000409	-	-
	<del>RN37E</del>	<del>0000002</del>	<del>0003031</del>		<del>0003116</del>
	RN33E	0000002	0009968	0009969	0010608
	<del>RN37N</del>	<del>0000002</del>	<del>0000801</del>	<del>0000802</del>	<del>0000836</del>
	RN33N	0000002	0002097	0002098	0002101
<del>RN37Y</del>	<del>0000009</del>	<del>0000831</del>	<del>0000832</del>	<del>0000865</del>	
RN33Y	0000011	0002842	0002843	0003072	
MT09A	RN296	0000301	0014544	0014545	0014568
	RN297	0000301	0002930	0002931	0002931
	RN298	0000301	0000555	-	-
	RN29L	0000001	0000767	-	-
	RN441	0000005	0000096	0000097	0000124
MT09TRA FJ09	RN29F	0000301	0013375	0013376	0015338
	RN29G	0000301	0003512	0003513	0003515
	RN29H	0000301	0000390	-	-
	RN29K	0000004	0000655	0000656	0000695
	<del>RN33E</del>	<del>0000002</del>	<del>0009968</del>	<del>0009969</del>	<del>0010608</del>
	RN37E	0000002	0003031	0003032	0003116
	<del>RN33Y</del>	<del>0000002</del>	<del>0002097</del>	<del>0002098</del>	<del>0002101</del>
	RN37N	0000002	0000801	0000802	0000836
<del>RN33Y</del>	<del>0000011</del>	<del>0002842</del>	<del>0002843</del>	<del>0003072</del>	
RN37Y	0000009	0000831	0000832	0000865	

## IDENTIFY IMPROVEMENT KIT (1 & 2) :

1RC-12210-09 (KIT 1)



1RC-12210-08 (KIT 2)



## INSTALLATION PROCEDURE :

Reference is made only for the procedure that does not exist in the manual.

### Procedure for KIT 1:



Εφαρμόστε λάδι στο σώμα του τεντωτήρα.



Τοποθετήστε τη φλάντζα και το δαχτυλίδι (1RC-14533-09)

\*Η φλάντζα δεν μπαίνει μετά το δαχτυλίδι



Τοποθετήστε τον τεντωτήρα με το άνοιγμα του δαχτυλιδιού προς την κάτω πλευρά του κινητήρα.

End gap



Ίσως δυσκολευτείτε στην τοποθέτηση του τεντωτήρα λόγω ανοχών ανά περίπτωση. Σε αυτήν την περίπτωση σφίξτε από λίγο και εναλλάξ κάθε μία από τις βίδες του τεντωτήρα μέχρι αυτός να πατήσει στον στροφαλοθάλαμο.

Replace the right screw cap shown in figure with the screw, the flange and the housing provided in the kit. Tighten to 10Nm.

\* Remove grease from the accessories.

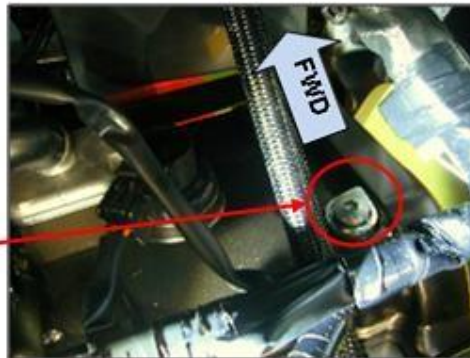
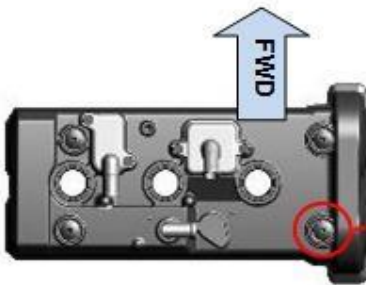

Before tightening the screw, align the casing with the cover, as shown in figure.

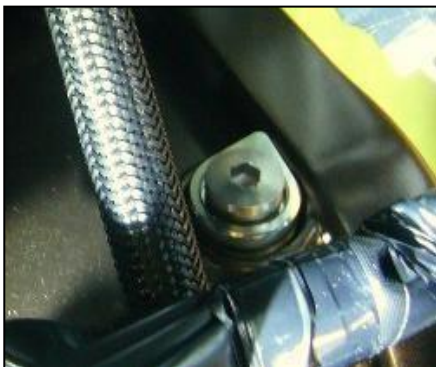

**ΣΗΜΕΙΩΣΗ :** Δώστε προσοχή στην τοποθέτηση της θήκης. Εάν δεν ευθυγραμμιστεί σωστά δεν θα περάσει λάδι προς τον τεντωτήρα.

## Procedure for KIT 2:

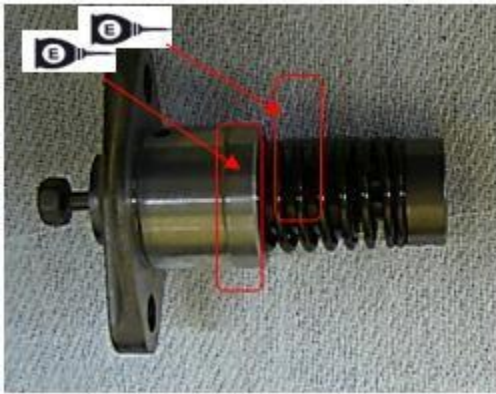

Εφαρμόστε λάδι στο σώμα του τεντωτήρα.

As in the process for kit 1, replace the right screw cap shown in figure with the screw, the flange and the housing provided in the kit. Tighten to 10Nm.

\* Remove grease from the accessories.



Before tightening the screw, align the casing with the cover, as shown in figure.

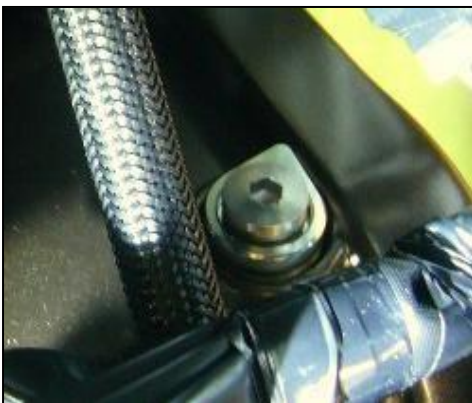

**ΣΗΜΕΙΩΣΗ :** Δώστε προσοχή στην τοποθέτηση της θήκης. Εάν δεν ευθυγραμμιστεί σωστά δεν θα περάσει λάδι προς τον τεντωτήρα

## WARRANTY :

Please insert standard warranty with the following symptom codes and work:

<b>Symptom Code</b>	17 (Noise)
<b>Manufacturer work</b>	1404 (Cam chain tensioner replacement)